

An Integrated Method of : Area Determination of Cross-Sections

Kubad Zeki Henari
Civil Engineering Dept., Engineering College,
University of Salahaddin-Erbil

ABSTRACT

An integrated method for determination of the areas from cross-sections of one level section, two level section and three level section was followed. The cases of section of cut only, fill only and partly cut and partly fill sections with their combinations between different types of cross-sections are considered to be fifty-eight cases. From these cases five main half sections generalize the calculation of the areas and the combination between them recovers all fifty-eight cases of the sections. Calculation of areas was performed using graphs and tables with simple multiplication and additions.

INTRODUCTION

The method for determination of volumes from cross-sections is the most widely used in engineering projects for all types and lends it self particularly well to route projects, roads, railways, waterways..., etc. The cross-sections are taken on lines at right angle to the main job centerline. Volume determination requires at first place, determination of cross-section areas, to be

used later for volume determination between adjacent sections.

This paper deals with an integrated method for area determination of different types of cross-sections (one level section, two level section and three level section) which generalize the tedious computation involved to simple, quick method.

Shapes of Cross-Sections

Cross-sections may be divided into four types with the respect to the existing natural ground[1,2]:

1. One level section: The ground is assumed, or agreed upon that is level transversely, (Fig.1-a).
2. Two level section: In this section the ground has uniform transverse gradient relative to the center line (since two levels are required to establish transverse uniform gradient), (Fig.1-b).
3. Three level section: The gradient of the ground of both sides of the centerline are not uniform (since three levels are required to establish two different gradient), (Fig.1-c).
4. Multi-level section: In this section the ground has more than three level along the cross-section line, (Fig.1-d).

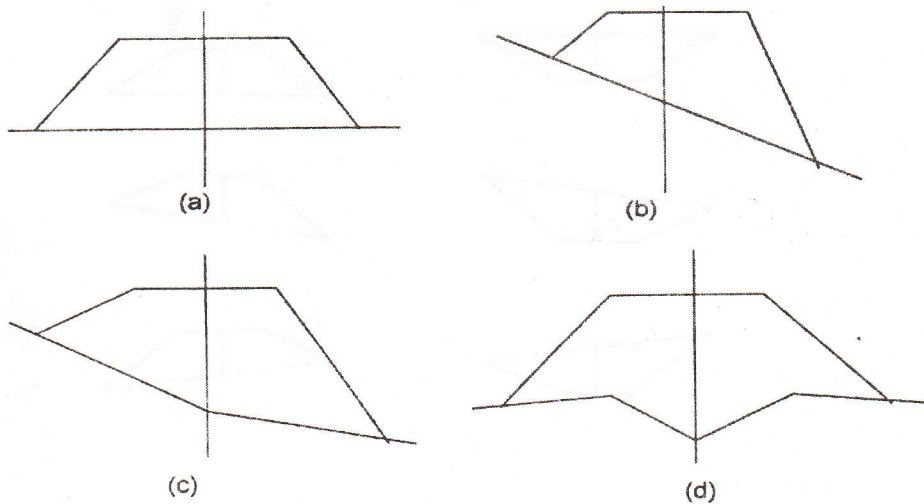

Fig.(1) Different Cross-Section Types

Types of Cross-Sections:

Cross-Section exist with:

1. Cross-sections with cutting only.
2. Cross-sections will filling (embankment) only.
3. Cross-sections partly cut and partly fill.

There are the following cutting sections, (Fig.2-a)

- One level section One case
- Two level section Two cases.
- Three level section Four cases.

There are the following filling section (Fig.2-b).

- One level section One case
- Two level section Two cases.
- Three level section Four cases.

There are the following sections with partly cut and partly fill. These sections are of three types:

First: Where $h=0$ at center line, (Fig.3-a,b)

- One level section Null
 - Two level section Two cases.
 - Three level section four cases.
- Second:** Where h is fill at center line (Fig.4-a,b and c)

- One level section Two cases
- Two level section Four cases.
- Three level section Nine cases.

Third: where h is cut at center line (Fig.5-a,b and c)

- One level section Two cases
- Two level section Four cases.
- Three level section Nine cases.

The combinations of half sections of one level sections with two level sections will give four cases of cutting section, (Fig.6-a) and four cases of filling sections (Fig.6-b).

The total cases may occur is fifty eight cases.

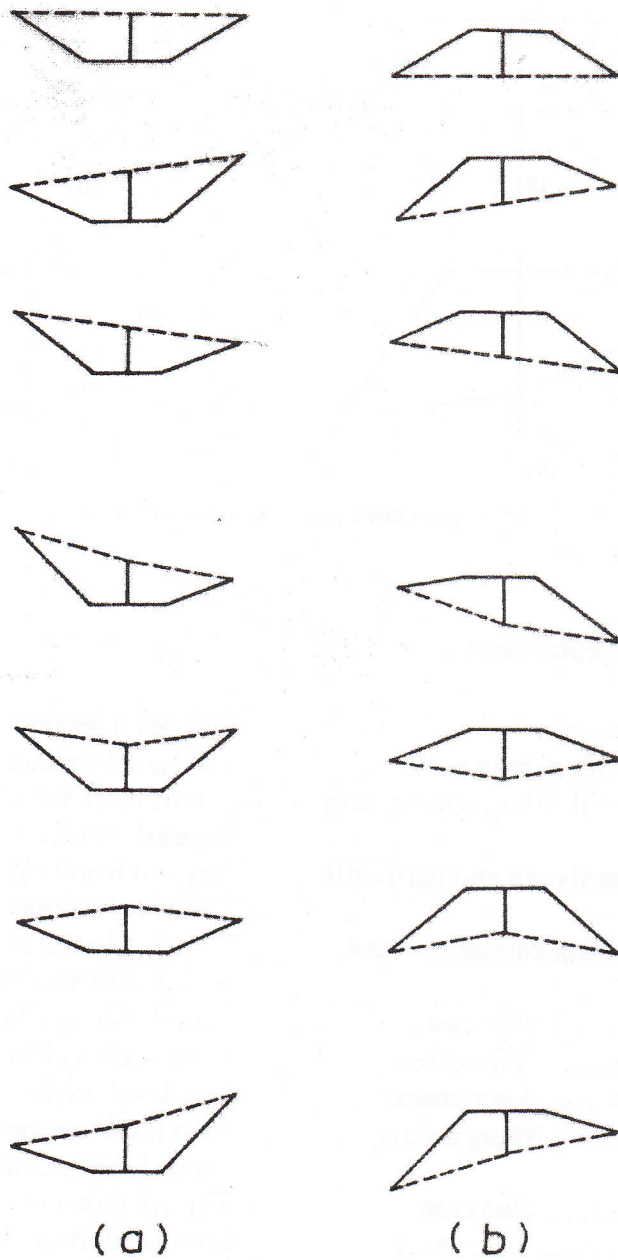
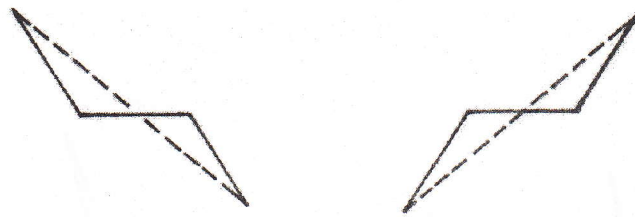

Fig. (2) Combination of Cutting and Filling Section



(a)



(b)

Fig. (3) Cross-Section Partially Cut and Partially Fill ($h = 0$)

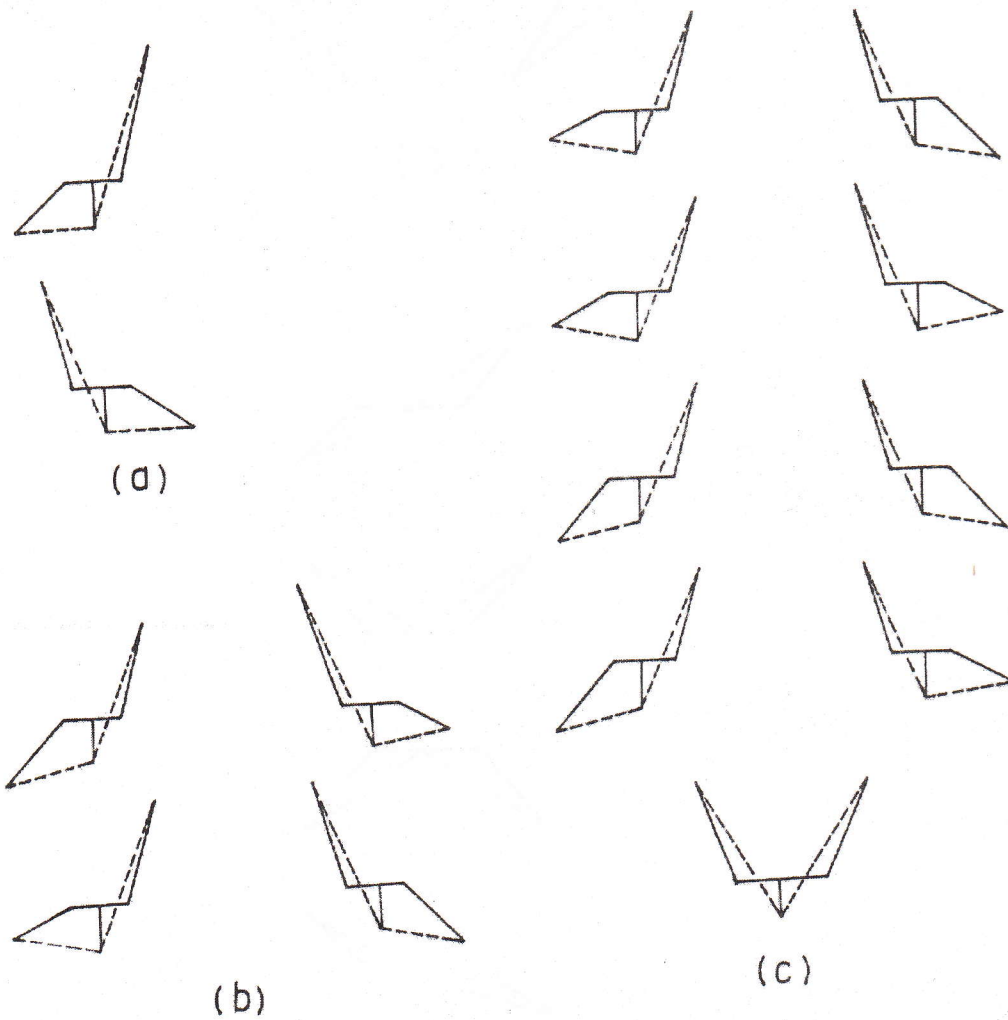

Fig. (4) Different Combinations of Cross-Sections Partially Cut and Partially Fill (h in Fill)

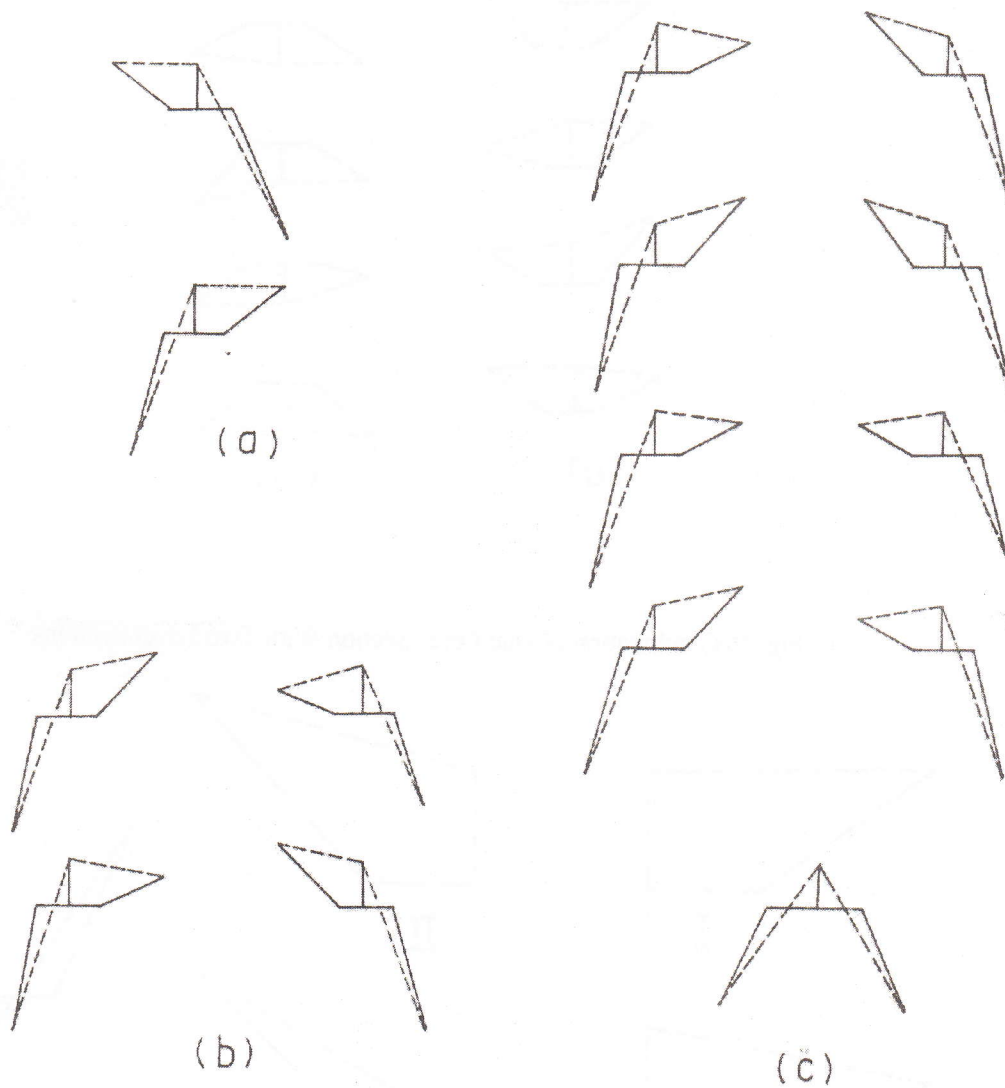

Fig.(5) Different Combination of Cross-Sections Partially Cut and Partially Fill (h in Cut)

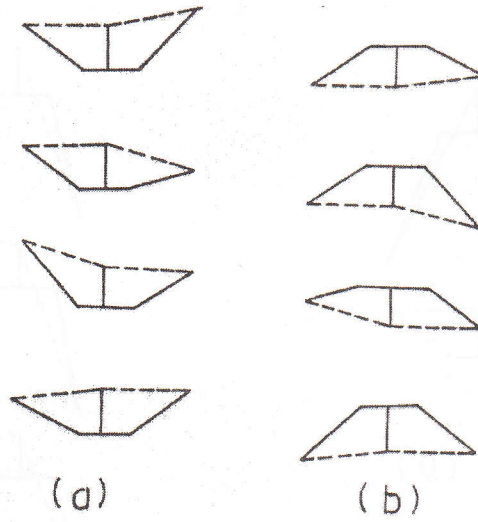

Fig.(6) Combination of One Level Section With Two Level Sections

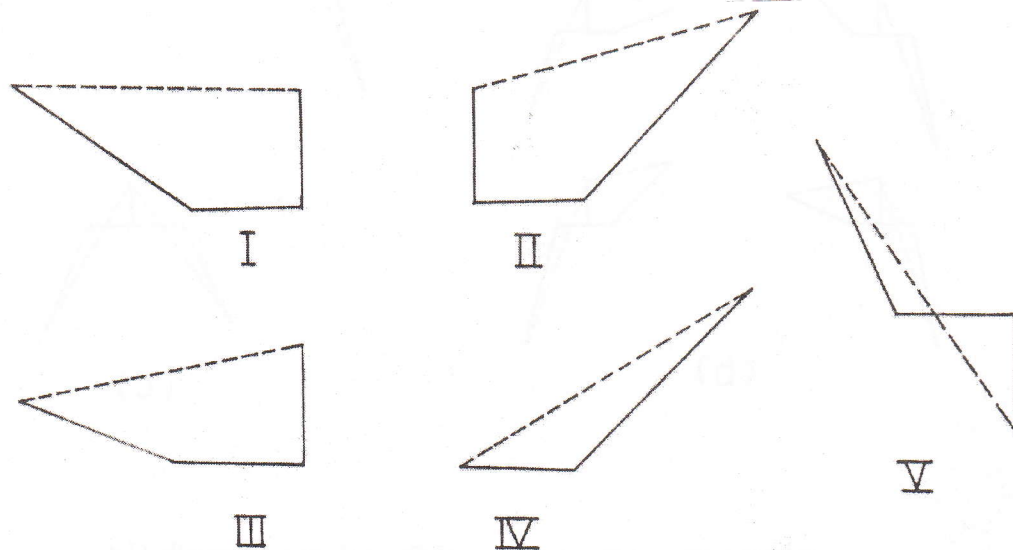

Fig. (7) Five Main Half Sections

Typical half sections:

If we look at these cases very closely we find five main half sections, Fig.7.

1. A half section of one level section (I).
2. A half section of two level section (II).
3. A half section of three level section (III).
4. A half section of two level section or three level section where $h=0$ (IV)
5. A half section of two level section or three level section where, there is cut or fill at center line (V).

Notation of elements of typical cross-section [1].

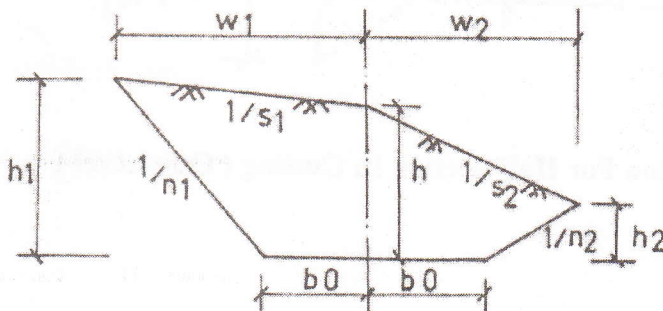

Fig. (8) Typical Cross-Section With Notation

- h : Depth at the center line.
- b_0 : Half of formation width.
- w_1 : Side width of the left side.
- w_2 : Side width of the right side.
- h_1 : Depth at the catch point of the left side.
- h_2 : Depth at the catch point of the right side.
- n_1 : Side slope of the left side of the design section.
- n_2 : Side slope of the right side of the design section.
- S_1 : Ground slope at the left side of the centerline.
- S_2 : Ground slope at the right side of the centerline.

Derivation of formulae (1)

1. In one level section: A half section with cutting (or filling).

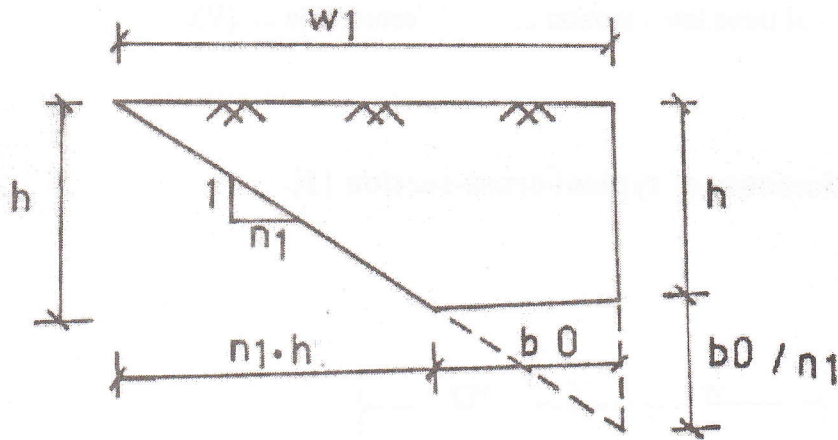

Fig.(9) Notation For Half Section In Cutting (One Level)

$$w_1 - b_0 = n_1 \cdot h$$

$$\frac{w_1 - b_0}{n_1} = h$$

$$\frac{w_1}{n_1} = h + \frac{b_0}{n_1}$$

$$w_1 = \left(h + \frac{b_0}{n_1} \right) n_1 \quad \dots\dots\dots(1)$$

$$\text{Area} = (1/2) w_1 \left(h + \frac{b_0}{n_1} \right) - \frac{b_0^2}{2n_1} \quad \dots\dots\dots(2)$$

2. In two level section: A half section with cutting (or filling).

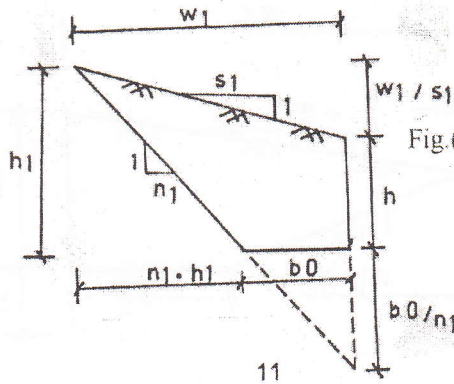

Fig.(10) Notation For Half Section In Cutting (Two Level)

$$n_1 h_1 = w_1 - b_0$$

$$h_1 = \frac{w_1 - b_0}{n_1} = h + w_1 / s_1$$

$$\frac{w_1}{n_1} - \frac{w_1}{s_1} = h + \frac{b_0}{n_1}$$

$$w_1 \left(\frac{1}{n_1} - \frac{1}{s_1} \right) = h + \frac{b_0}{n_1}$$

$$w_1 = \left(h + \frac{b_0}{n_1} \right) * \frac{s_1 n_1}{s_1 - n_1} \dots\dots\dots (3)$$

$$\text{Area} = 1 / 2 w_1 \left(h + \frac{b_0}{n_1} \right) - \frac{b_0^2 / 2}{n_1} \dots\dots\dots (4)$$

3. In three level : A half section with cutting (or filling).

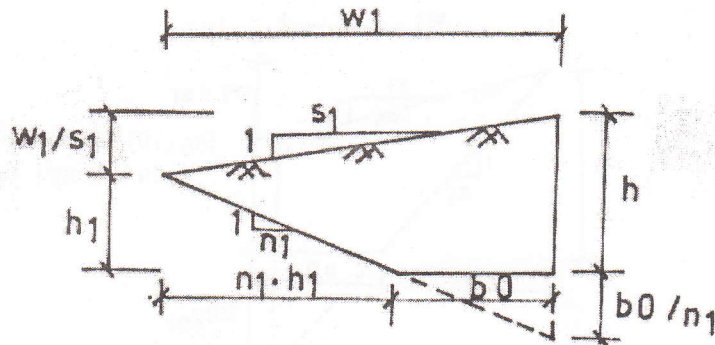

Fig.(11) Notation for Half Section in Cutting (Three Level)

$$n_1 h_1 = w_1 - b_0$$

$$h_1 = \frac{w_1 - b_0}{n_1} = h - \frac{w_1}{s_1}$$

$$\frac{w_1}{n_1} + \frac{w_1}{s_1} = h + \frac{b_0}{n_1}$$

$$w_1 \left(\frac{1}{n_1} + \frac{1}{s_1} \right) = h + \frac{b_0}{n_1}$$

$$w_1 = \left(h + \frac{b_0}{n_1} \right) * \frac{s_1 n_1}{s_1 - n_1} \dots\dots\dots(5)$$

$$\text{Area} = 1/2 w_1 \left(h + \frac{b_0}{n_1} \right) - \frac{b_0^2 / 2}{n_1} \dots\dots\dots(6)$$

4. Sections with partly cut and partly fill :

a) $h=0$

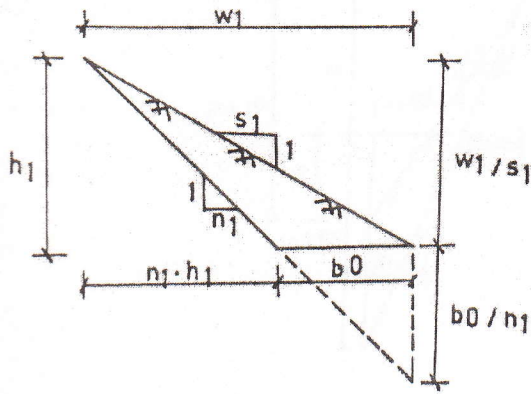

Fig.(12) Notation for Half Section in Cutting ($h = 0$)

$$n_1 h_1 = w_1 - b_0$$

$$h_1 = \frac{w_1 - b_0}{n_1} = w_1 / s_1 + 0$$

$$\frac{w_1}{n_1} - \frac{w_1}{s_1} = 0 + \frac{b_0}{n_1}$$

$$w_1 \left(\frac{1}{n_1} - \frac{1}{s_1} \right) = 0 + \frac{b_0}{n_1}$$

$$w_1 = \left(0 + \frac{b_0}{n_1} \right) * \frac{s_1 n_1}{s_1 - n_1} \dots\dots\dots(7)$$

$$\text{Area} = 1/2 w_1 \left(0 + \frac{b_0}{n_1} \right) - \frac{b_0^2 / 2}{n_1} \dots\dots\dots(8)$$

b) h = cut or fill

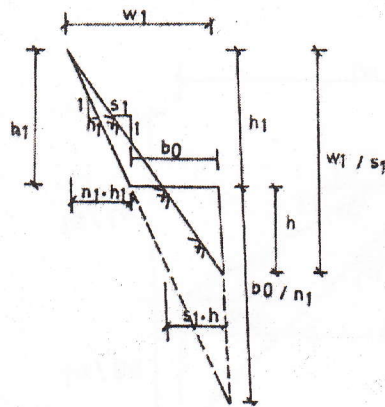

Fig.(13) Notation for Half Section in Cut and Fill (h = Cut or Fill)

$$n_1 h_1 = w_1 - b_0$$

$$h_1 = \frac{w_1 - b_0}{n_1} = w_1 / s_1 - h$$

$$\frac{w_1}{n_1} - \frac{b_0}{n_1} = h$$

$$w_1 \left(\frac{1}{n_1} - \frac{1}{s_1} \right) = \frac{b_0}{n_1} - h$$

$$w_1 = \left(\frac{b_0}{n_1} - h \right) * \frac{s_1 n_1}{s_1 - n_1} \dots\dots\dots(9)$$

$$AF = 1/2 s_1 h^2 \dots\dots\dots(10)$$

$$AC = 1/2 w_1 \left(\frac{b_0}{n_1} - h \right) - \frac{b_0^2 / 2}{n_1} + 1/2 s_1 h^2 \dots\dots\dots(11)$$

Area determination: A methodology[1,2,3]

Available data: for area determination data must be collected from field measurement as follows :

- Elev.1: Elevation of the natural ground at the left side of the center line of the section which lies at the distance (D1) from the center line.
- Elev.C: Elevation of the natural ground at the center line of the section.
- Elev.2: Elevation of the natural ground at the right side of the center line of the section which lies at the distance (D2) from the center line (usually D1=D2). From geometric design: Formation width (2bo), side slopes of left and right side of the section(n1,n2) (These values remains constant for a great extend). The grade line level at each station (i.e section).

Identification of the sections: The identification of the sections requires the following calculations:

a- $\Delta H1 = \text{Elev.C} - \text{Elev.1}$

If the sign is positive, this means that the ground at the left side of the section is falling away from the center line,(Fig.7-III).

If the sign is negative, this means that the ground at the left side of the section is rising away from the center line, (Fig.7-V)

If the result equals to zero, this means that the ground at the left side of section is horizontal, (Fig.7-I.)

b- $\Delta H2 = \text{Elev.C} - \text{Elev.2}$

If the sign is positive, this means that the ground at the right side of the section is falling away from the center line.

If the sign is negative, this means that the ground at the right side of the section is rising away from the center line, (Fig.7-II,IV)

If the result equals to zero, this means that the ground at the right side of section is horizontal.

c- $h = \text{Elev.C} - \text{Design level of the section.}$

If the sign is positive, this means that there is cut at the center line of the section.

If the sign is negative, this means that there is fill at the center line of the section.

If the result equals to zero, this means that there is no cut, no fill at the center line of the section (i. e. The grade line and natural ground level have same elevation).

d- To find out weather the section is completely cut or fill or contain partly cut, partly fill requires the following calculations.

$S1 = 1/\Delta H1 * D1 \dots\dots\dots(12)$

$S2 = 1/\Delta H2 * D2 \dots\dots\dots(13)$

$h * S1$ if it is less than b_o , the left side of the section contains partly cut and partly fill (Fig.7-V).

Then $h * S2$ if it is less than b_o , the right side of the section contains partly cut and partly fill.

From the steps (a,b,c and d) above the following information about the cross- section may be obtained.

1. Kind of the section.

2. Nature of the sections(containing cut or fill only or partly cut and partly fill).

- Calculation of w_1 and w_2 and other unknown values from :

a. $w_i = \left(\frac{b_o}{n_i} \pm h \right) \left(\frac{s_i n_i}{s_i \pm n_i} \right) \quad i = 1,2$

b. $\left(\frac{b_o}{n_i} \pm h \right)$ -From the graph (Fig.14)

c. $\left(\frac{b_o}{n_i} + h \right)$ - For half sections (I,II,III,IV) (Fig.7)

d. $\left(\frac{b_o}{n_i} - h \right)$ -For half section (V) (Fig.7)

e. $\frac{b_o}{n_i}$ is the distance upward from (b_o) at the ordinate to gradient (n).

f. h is the distance down ward from (b_o) at the ordinate to required (h).

g. The total gives $\left(\frac{b_o}{n} + h \right)$

h. The difference between them gives $\left(\frac{b_o}{n} - h \right)$

i. $\frac{s_i n_i}{s_i \pm n_i}$ From Table - 1

j. $\frac{s_i n_i}{s_i \pm n_i}$ From half sections III (Fig.7)

k. $\frac{s_i n_i}{s_i \pm n_i}$ From half sections II, IV, V (Fig.7)

From the values of s_i and n_i we may locate as the coordinate system ($s_i n_i / s_i \pm n_i$) values.
 The upper figures for ($s_i n_i / s_i + n_i$)
 The lower figures for ($s_i n_i / s_i - n_i$)

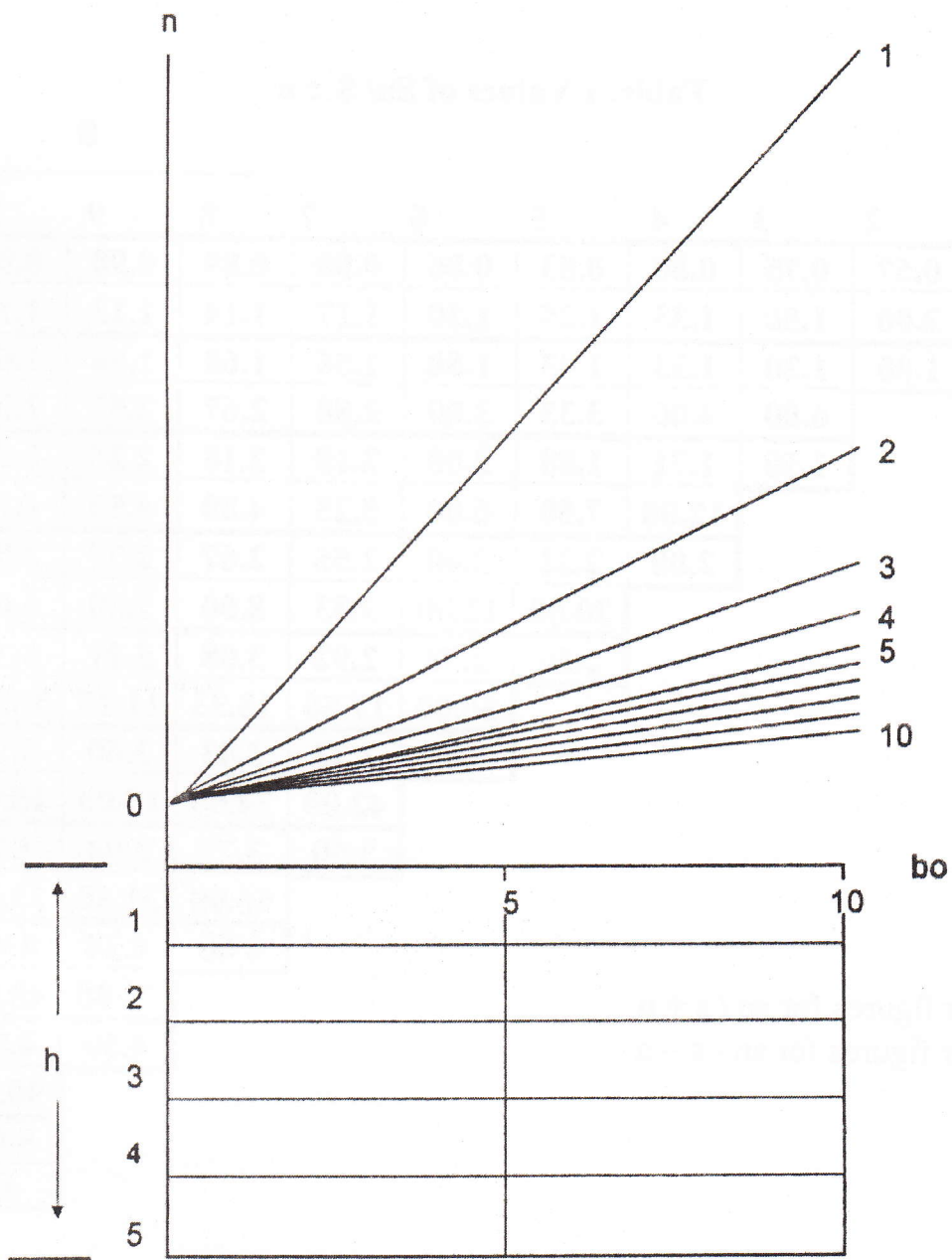

$$b_0 / n \pm h$$

(Fig. 14) Graph shows relative between ((h), (n)) & (b₀) for obtaining (boln ± h)

Table. 1 Values of $S_n / S \pm n$

										S	
1	2	3	4	5	6	7	8	9	10	n	
0.50	0.67	0.75	0.80	0.83	0.86	0.88	0.89	0.90	0.91		
	2.00	1.50	1.33	1.25	1.20	1.17	1.14	1.13	1.11	2	
	1.00	1.20	1.33	1.43	1.50	1.56	1.60	1.64	1.67	3	
		6.00	4.00	3.33	3.00	2.80	2.67	2.57	2.50	4	
		1.50	1.71	1.88	2.00	2.10	2.18	2.25	2.31	5	
			12.00	7.50	6.00	5.25	4.80	4.50	4.29	6	
			2.00	2.22	2.40	2.55	2.67	2.77	2.86	7	
				20.00	12.00	9.33	8.00	7.20	6.67	8	
				2.50	2.73	2.92	3.08	3.21	3.33	9	
					30.00	17.50	13.33	11.25	10.00	10	
					3.00	3.23	3.43	3.60	3.75		
						42.00	24.00	18.00	15.00		
						3.50	3.77	3.94	4.12		
							56.00	31.50	23.33		
							4.00	4.24	4.44		
								72.00	40.00		
								4.50	4.74		
									90.00		
									5.00		
									E		

Upper figures for $s_n / s + n$
 Lower figures for $s_n / s - n$

The product of the out put of these two main parts of the main formula will produce w_i (where $i = 1,2$)

Calculation of Area from: .

a) $A = 1/2 w_i \left(\frac{b_o}{n_i} + h \right) - \frac{b_o^2 / 2}{n_i}$ for half (Section I, II, III, IV)

wi obtained from Fig.(14) and Table-1

$\frac{b_o}{n_i} + h$ obtained from Fig.(14)

To obtain $(b_o^2 / 2) / n_i$ use table.2.

$(b_o^2 / 2) / n_i$ read directly from the table then divided by multiplication of the first and second part divided by two then subtracted fi om the third part will give the area of ,cut or fill only.

$A = 1 / 2 w_i \left(\frac{b_o}{n_i} - h \right) - \frac{b_o^2 / 2}{n_i} + 1 / 2 s_i h^2$

wi obtained from Fig.(14) and Table-1

b_o known

$\left(\frac{b_o}{n_i} - h \right)$ Obtained Fig.(14)

$\frac{b_o^2}{2}$ obtained from Table(2)

To obtain $1/2 s_i h^2$ use table.3 directly or by interpolation. This is the cut or fill part of the section. Then the result is used in the main formula to obtain the area of cut or fill.

Table -2 For obtaining value of (b_o² / 2)

	1	2	3	4	5	6	7	8	9	10
b _o ²	0.50	2.00	4.50	8.00	12.50	18.00	24.50	32.00	40.50	50.00
n	1	2	3	4	5	6	7	8	9	10

Table -3 For obtaining value of (1 / 2 s h²)

S

	1	2	3	4	5
h	4	8	12	16	20
	9	18	27	36	45
	16	32	48	64	80
	25	50	75	100	125

Best results can be obtained by tabulation of the information's obtained from above as follows :

Stations	$\frac{b_0}{h}$	$\frac{n_1}{s_1}$	$\frac{n_2}{s_2}$	Type	$\frac{b_0}{n} \pm h$	$\frac{S_n}{S_{\pm n}}$	$\frac{w_1}{w_2}$	$\frac{b_0^2 / 2}{n}$	$\frac{Ac}{A_F}$

CONCLUSIONS

- 1- The proposed method is easy for performing any type of required cross-sections from five main half sections.
- 2- The method reduces the tedious computation required specially when large number of cross-sections are to be considered.
- 3- Large part of calculations are obtained directly from Fig.(14), Table-1, Table-2 and Table-3
- 4- Datas (w 1, w2) may be obtained from this method easily for slope - staking instead drawing large number of cross-sections or following other field methods used for this purpose.
- 5- The method is programmable in computers.

REFERENCE

- 1- ALLAN, HOLLWEY, and MAYNES "Practical Field Surveying And Computation " William Heineman Ltd., 1977.
- 2- HARRY BOUCHARD "Surveying" - Fifth Edition - International Text Book Company, 1965.
- 3- JAWAHAR LAL SHARMA "Text Book Of Surveying " CBS Publisher And Distributor, 1985.

رینگه یه کی یه کگرتوو بو دۆزینه وهی پووبه ری به شی بر او

قوباد زه کی هه ناری
کۆلیجی نه نازیار ی / زانکۆی سه لاهه دین

کورتته

له م توێژینه وه یه دا رینگه یه کی یه کگرتوو پیشک شه کر او ه بو دۆزینه وه ی پووبه ری به شی بر او ی یه ک ناست ، دوو ناست وه سی ناست له گه ل به شی ته نها بر او یان ته نها پر کر او ه یان هه ردوکیان . پووبه ر دۆزینه وه کان به ناسانی به جی نه هینریت رینگه ی خشته و هیل ی چه ماوه یی ناماده کر او ه به کۆکردنه وه و لیک دانی ناسان .

طريقة متكاملة لحساب مساحة المقاطع

قباد زکی هه ناری
کلیه الهندسه / جامعه صلاح الدین

الخلاصة

يقدم البحث طريقة متكاملة لإيجاد المساحة لمقاطع ذات مستوى واحد ، أو اثنان أو ثلاثة وكذلك لمقاطع الحفر أو الإغلاء أو كليهما . يتم احتساب هذه الطريقة بواسطة المنحنيات والجداول وإجراء حسابات بسيطة .